

HW Hose Clamps - slim Clamps

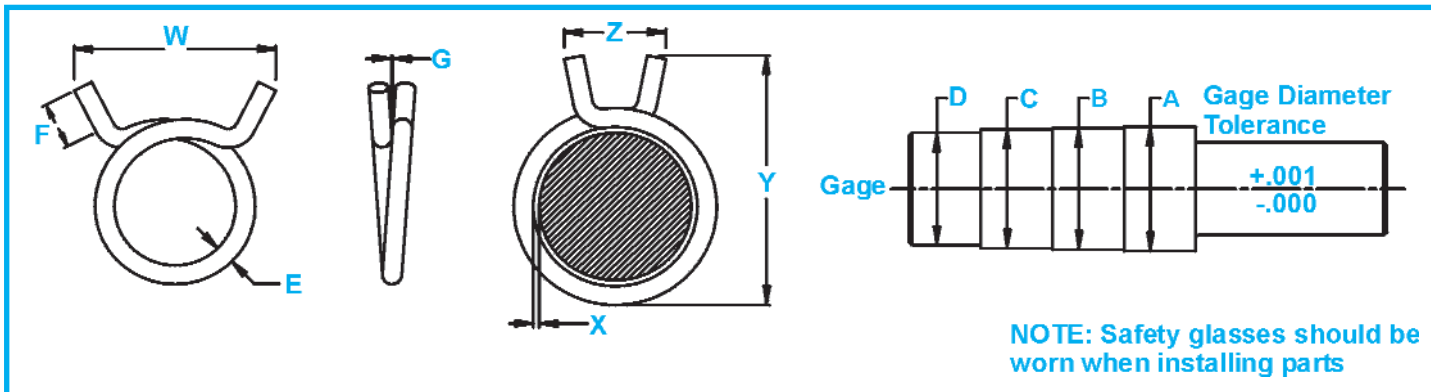

EFFECTIVE CLAMPING RANGE: After expanding to no greater than “A” diameter of the gage, the clamp in relaxed condition shall not pass over “D” diameter. When clamp is assembled on “A,” “B” or “C” diameter of gage, a wire of “X” diameter shall not pass between gage and clamp when inserted in a direction parallel to the axis of the gage.

FINISH: Peen-Plate Zinc (non-electrolytic process) .0002 minimum thickness plus dichromate treatment.

MATERIAL: Specially processed premium grade spring wire, hardened and austempered to meet the performance requirements specified.

Note: All Dimensions are in inches.

Rotor Clamp HC No.	Case Quantity Min. 1 case	Approx. Case Weight (lbs.)	E Nom. Wire Dia.	EFFECTIVE CLAMPING RANGE				X Dia. Gaging Wire	G Clearance at overlap Max.	F Length of Tangs	W Width over Tangs Max.	Z Width over Tangs when on a Dia.	Y Overall Height (Ref. Only)	Color Code *	Pneumatic Installation Tool		
				A Max. Dia.	B Nom. Dia.	C Min. Dia.	D No-Go Gage Dia.										
HW-9	8000	39	.082	.573	.562	.551	.520	.006	.025	1/4	+ .000-1/32	1-1/16	.415	+ .020-.000	1.25	ZD	PWS-9
HW-11	6000	33	.087	.703	.688	.671	.635	.006	.025	1/4	+ .000-1/32	1-1/8	.425	+ .020-.000	1.38	R	PWS-11
HW-12	5000	30	.087	.770	.750	.730	.690	.008	.031	1/4	+ .000-1/32	1-3/16	.425	+ .020-.000	1.38	ZD	PWS-12
HW-13	4000	28	.092	.832	.812	.792	.740	.008	.031	1/4	+ .000-1/32	1-1/4	.410	+ .020-.000	1.38	G	PWS-13
HW-14	3000	26	.092	.900	.875	.850	.800	.008	.031	1/4	+ .000-1/32	1-1/4	.410	+ .020-.000	1.49	R	PWS-14
HW-16	2500	29	.107	1.031	1.000	.969	.915	.008	.062	1/4	±1/32	1-1/2	.510	+ .020-.000	1.75	G	PWS-16
HW-18	1700	28	.122	1.150	1.125	1.100	1.030	.010	.062	1/4	±1/32	1-5/8	.525	+ .020-.000	1.88	ZD	PWS-18
HW-19	1400	24	.122	1.218	1.187	1.152	1.095	.010	.062	1/4	±1/32	1-5/8	.510	+ .020-.000	1.88	G	PWS-19
HW-20	1400	23	.122	1.280	1.250	1.219	1.145	.010	.062	1/4	±1/32	1-3/4	.525	+ .030-.000	1.88	R	PWS-20
HW-21	1300	28	.132	1.344	1.312	1.281	1.210	.010	.062	1/4	±1/32	1-3/4	.540	+ .030-.000	2.19	ZD	PWS-21
HW-22	1000	22	.132	1.406	1.375	1.344	1.250	.010	.062	1/4	±1/32	1-7/8	.540	+ .030-.000	2.19	G	PWS-22
HW-23	1000	23	.132	1.468	1.437	1.406	1.300	.010	.062	1/4	±1/32	1-7/8	.525	+ .030-.000	2.19	R	PWS-23
HW-24	1000	24	.132	1.531	1.500	1.469	1.350	.010	.062	1/4	+1/16-.000	1-7/8	.540	+ .030-.000	2.25	ZD	PWS-24
HW-26	900	27	.142	1.672	1.625	1.578	1.455	.010	.062	1/4	±1/16	2	.580	+ .030-.000	2.56	ZD	PWS-26

* GREEN, R-RED, ZD-DICHROMATE (YELLOW)