

INNOVATIVE
LIGHTING inc.[®]



Inc. 500



In 2002, 2003 and again in 2004, Innovative Lighting has been named by INC. Magazine as one of the nation's top 500 fastest growing companies.



Jerry Handsaker, President of Innovative Lighting Inc. received the 2004 Iowa / Nebraska Region Ernst & Young Entrepreneur Of The Year® award. More than 3,000 people across the United States are nominated annually for the prestigious Ernst & Young awards program. Of these nominees, approximately 350 are honored as outstanding entrepreneurs. Handsaker said, "This award reflects on the outstanding effort made by each and every employee of Innovative Lighting."



Innovative Lighting received the Innovation Award for their new battery-operated Hand Held Signaling Horn. They received this award during the 2003 MAATS show held in July in Las Vegas, NV. This award was presented by the National Marine Manufacturers Association.



The 2003 Boatkeeper Award was presented by the Editor-in-Chief of MotorBoating Magazine to Innovative Lighting for their Hand Held Signaling Horn. This award is given for the most functional gear and accessories designed to make the boat owner's life easier.

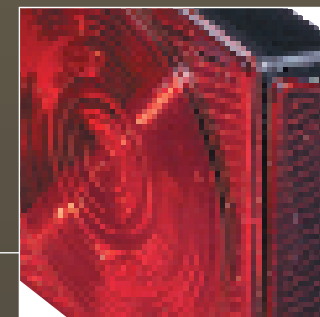
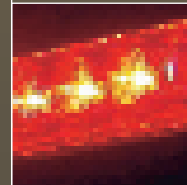
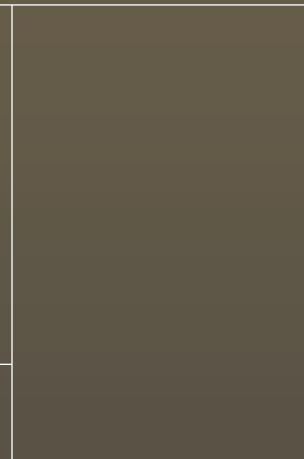

COMMITMENT TO EXCELLENCE

It is our conviction that to be the best is not sufficient for that is only a comparison to the standards of others.



MISSION STATEMENT

To produce innovative, value intensive products by cultivating the creativity and capabilities of dedicated employees who support the common goal of creating and maintaining satisfied customers.

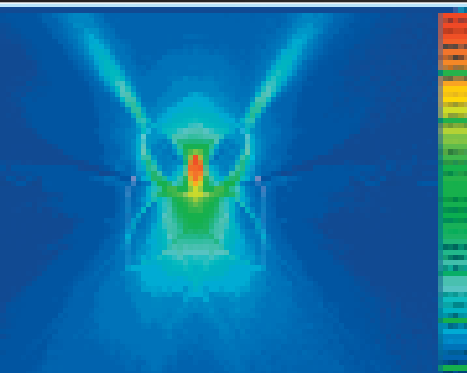

Lens Optimization

Innovative Lighting develops and designs energy efficient, cost effective lighting products. Using sophisticated lens software, we collect, measure, and redistribute the light energy (source) to a calculated surface. Our virtual modeling system optimizes the lens design so the light output loses the least amount of light energy assuring an accurate and reliable optical system.

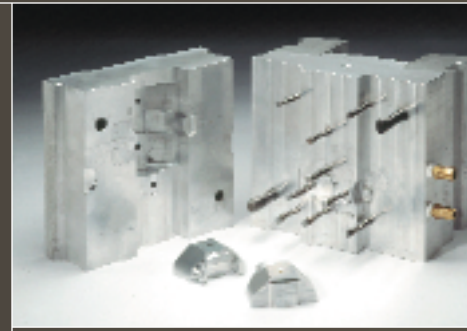

Proto-Type Molds

Innovative Lighting can produce cost effective and accurate prototype molds machined to manufacture plastic components from any specified thermoplastic material. This service is ideal for producing high-quality, low volume parts that do not warrant expensive hardened tool steel dies.

CAD / Design Services

Innovative Lighting utilizes the latest computer aided engineering software, including ProE, Solid Works, Trace Pro, Mold Flow, and TFCalc, to create three-dimensional (3-D) solid databases enhanced by Innovative's own optical software for lens optimization. This database allows for modifications and designs that are tailored to meet customer and industry specifications.



Injection Molding Services

Innovative Lighting manufactures and produces precise, high quality molded components from our state-of-the-art electric and hydraulic presses that meet and exceed customer expectations.



Rapid Proto-Typing

Innovative Lighting uses the latest in technology to produce 3-D Selective Laser Sintering (SLS) prototypes from computer generated databases. Innovative, as well as our customers, may compress development time, reduce tooling costs, refine and test functional SLS parts into a matter of days. Innovative provides a high speed Internet link with secure FTP sites to accept database files in STL, Iges, and ProE formats.

Multiple materials can be used to satisfy customer specific requirements including...

- Duraform (Nylon)
- Somos (Flexible Elastomer)
- Glass-filled Duraform
- Castform (Polystyrene / Wax)



Precision Assembly

Innovative Lighting performs all of its assembly processes in a controlled environment to assure proper set-up and curing time. Components are designed, measured, and monitored to meet our stringent specifications.

Distribution / Packaging

Innovative Lighting carries a complete finished goods inventory in bulk and point-of-purchase retail packaging. Our products are sold worldwide through a select network of professional independent sales representatives and distributors.



Proto-Type Finishing

Innovative Lighting produces fully finished prototypes useful for your engineering, marketing or testing requirements.

Innovative can create a high profile prototype that appears completely finished, commercial ready, and fully functional.

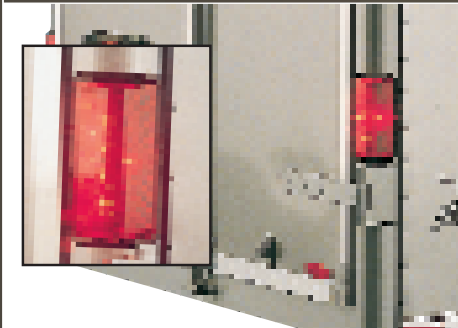

Proprietary Custom LED Applications

Innovative Lighting offers complete engineering assistance in designing, prototyping and manufacturing proprietary LED lighting applications in accordance with DOT/SAE and FMVSS 108 standards. All safety LED lighting products are independently third party certified.

Light Emitting Diode, more commonly known as "LED", represents the cutting edge of lighting technology. LEDs operate on a totally different concept than traditional incandescent style lights. Instead of using a brittle metal filament that is susceptible to shock and vibration, LEDs are solid-state devices with no moving parts utilizing an electronic chip that is encapsulated in an epoxy substrate. This design provides increased durability and a protective seal against outside or foreign elements.

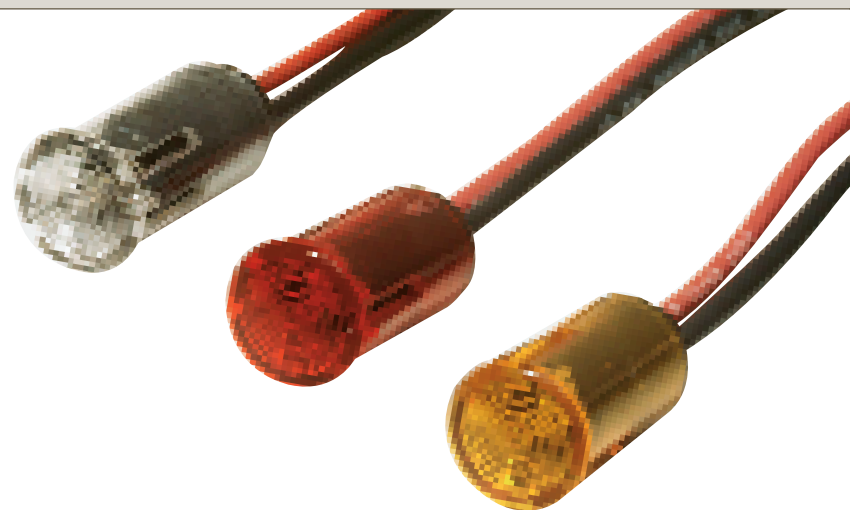

Efficiency

LED's are very energy efficient and consume less power (amp draw)...up to 90% less power than incandescent bulbs. This reduces the load on your electrical system including your battery, alternator, and power converter resulting in direct money-saving benefits.

No Heat

LED lights generate no heat therefore they are cool to the touch and can be left on for hours without incident or consequence if touched.

Longevity

LEDs are rated for 100,000 hours compared to 3,000 hours for incandescent bulbs. Consider real world circumstances where most incandescent bulbs need to be replaced within one year. An LED light will last over 20 years before needing a replacement.

Fusing

Due to the low energy draw of LEDs, the gauge of wire used can be reduced. **CAUTION: Typical incandescent fusing requirements are too robust for LEDs and therefore, fusing must be sized for the low LED circuit draw. Incorrect fuse sizing can cause damage to your electrical system.** Innovative's Electronic Engineering Staff can assist you when sizing your fuse requirements.

Future

LEDs are vastly becoming the preferred low voltage lighting resource versus incandescent lighting. New and brighter LEDs are under development and will impact your future lighting requirements.

Innovative Lighting is recognized as a leading design and manufacturing company specializing in quality LED lighting applications and solutions.

Take advantage of the many benefits of LED lighting and the proven experience of Innovative Lighting.

Know Your A<B<Cs

LED's are measured by an "alpha number", also known as, a "bin" number. For example A,B,C, etc... the higher the alpha or bin number, the higher the intensity. The color of light and consistency of light varies with manufacturers. Innovative Lighting uses only approved manufacturers meeting our stringent design and quality specifications.

SAFETY

Improved safety may be LED's most important benefit, as they provide instantaneous and brighter illumination compared to incandescent bulbs that require more burn time when illuminated.

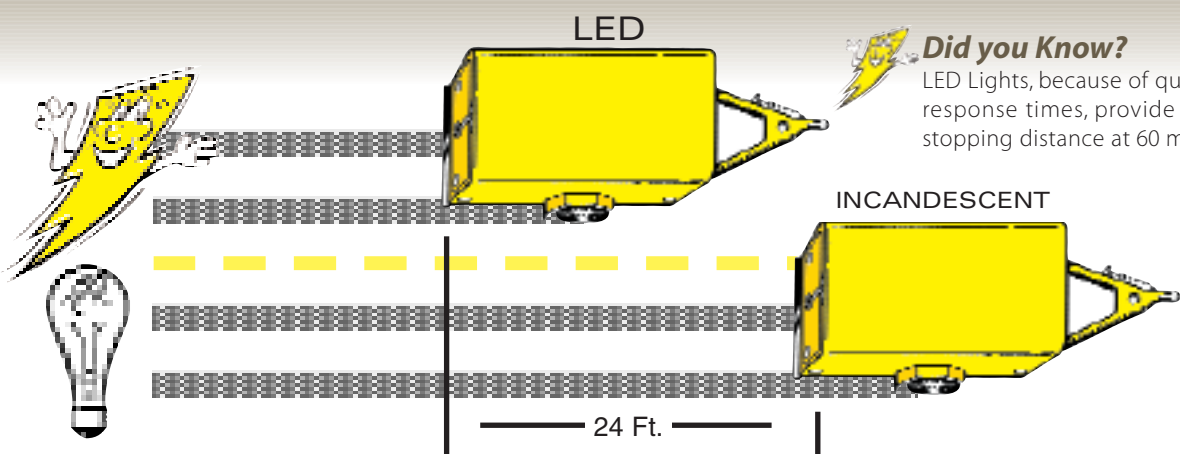

Did you Know?

LED Lights, because of quicker and brighter response times, provide an extra 24 feet of stopping distance at 60 miles per hour.

IMAGINATION <i>L.E.D. Series Care-Free Luminaires</i>	7-8	
ILLUMINATION <i>LED/Fluorescent Lights</i>	9-10	
SIMPLICITY <i>L.E.D. Marker Lights</i>	11-14	
AWARENESS <i>L.E.D. Identification Bars</i>	15-18	
INNOVATION <i>L.E.D. Tail Lights/Kits</i>	19-21	
REFLECTIONS <i>Strobes and Reflectors</i>	22	
VISION <i>L.E.D. Navigation Lights</i>	23-26	
INTENSE <i>Piezo Signaling Devices</i>	27-28	
FIRST-CLASS <i>Portable Navigation Lights</i>	29-30	
CRAFTSMANSHIP <i>Docking/Backup Lights</i>	31	
REVOLUTIONARY <i>L.E.D. Deck/Dock Kits</i>	32	
PRESENTATION <i>P.O.P Packaging</i>	33	
ANSWERS <i>Information and Warranty</i>	34	



Single LED Accent Surface Mount Lights

- Operates 9-16 Volt DC Systems
- 24 Volt Version Available
- Size: 1.57" L x .82" W x .57" D
- Rated @ 200,000 Hours of Service Life
- Shock and Vibration Proof
- Cool to the Touch
- Energy Draw 26 Milliamps
- No Corrosion
- Potted to Seal Out Moisture
- 1 LED
- Patent #D443377

Product Numbers

- See Chart for Case Color Options
- Model No.: 001-1x00 Amber
 - Model No.: 001-2x00 Blue
 - Model No.: 001-3x00 Green
 - Model No.: 001-4x00 Red
 - Model No.: 001-5x00 White
 - Model No.: 001-6x00 Purple
 - Model No.: 001-7x00 Orange
 - Model No.: 001-8x00 Teal

Bulk Std. Pack Qty = 12
Packaged Std. Pack Qty = 12



3-LED Step Surface Mount Lights

- Operates 9-16 Volt DC Systems
- 24 Volt Version Available
- Size: 1.71" L x .65" W x .40" D
- Rated @ 200,000 Hours of Service Life
- Shock and Vibration Proof
- Cool to the Touch
- Energy Draw 26 Milliamps
- No Corrosion
- Potted to Seal Out Moisture
- 3 LEDs
- Patent #D440673

Product Numbers

- See Chart for Case Color Options
- Model No.: 003-1x00 Amber
 - Model No.: 003-2x00 Blue
 - Model No.: 003-3x00 Green
 - Model No.: 003-4x00 Red
 - Model No.: 003-5x00 White
 - Model No.: 003-6x00 Purple
 - Model No.: 003-7x00 Orange
 - Model No.: 003-8x00 Teal

Bulk Std. Pack Qty = 12
Packaged Std. Pack Qty = 12



4-LED Courtesy Surface Mount Lights

- Operates 9-16 Volt DC Systems
- 24 Volt Version Available
- Size: 1.57" L x .82" W x .57" D
- Rated @ 200,000 Hours of Service Life
- Shock and Vibration Proof
- Cool to the Touch
- Energy Draw 26 Milliamps
- No Corrosion
- Potted to Seal Out Moisture
- 4 LEDs
- Patent #D443377

Product Numbers

- See Chart for Case Color Options
- Model No.: 004-1x00 Amber
 - Model No.: 004-2x00 Blue
 - Model No.: 004-3x00 Green
 - Model No.: 004-4x00 Red
 - Model No.: 004-5x00 White
 - Model No.: 004-6x00 Purple
 - Model No.: 004-7x00 Orange
 - Model No.: 004-8x00 Teal

Bulk Std. Pack Qty = 12
Packaged Std. Pack Qty = 12



LED COLOR OPTIONS

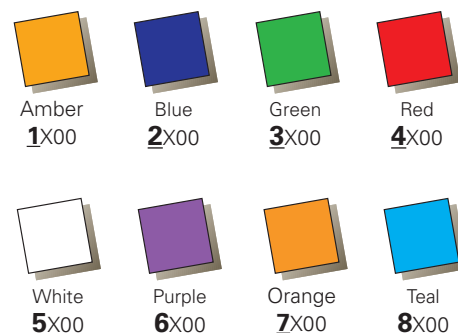

CASE COLOR OPTIONS



LIGHT SIZING



3-white LED Portable Battery Operated Lights

- 3-AAA Batteries Required
- Size: 2.40" L x 1.78" W x 1.33" D
- Built-in On/Off Switch
- Snap On/Off Battery Cover
- Super Light Weight
- Cool to the Touch
- Velcro Mounting Strips Included
- 3 LEDs

Product Numbers

- Model No.: 005-5000 Black Case
- Model No.: 005-5010 Black Case w/ Wedge & Bracket
- Model No.: 005-5020 Black Case w/ Clip
- Model No.: 005-5100 Green Case
- Model No.: 005-5120 Green Case w/ Clip
- Model No.: 005-5200 Yellow Case
- Model No.: 005-5220 Yellow Case w/ Clip
- Model No.: 005-9910 Wedge & Bracket Only

Bulk Std. Pack Qty = 24
Packaged Std. Pack Qty = 10



LED Day Bright Indicator Recess Mount Lights

- Operates 9-16 Volt DC Systems
- Size: .56 OD x .50" ID x 1.29" L
- Rated @ 100,000 Hours of Service Life
- Requires 1/2" (.50) Hole
- Shock and Vibration Proof
- Cool to the Touch
- No Corrosion
- 1 LED

Product Numbers

- Model No.: 010-1100 Amber w/ Amber Lens
- Model No.: 010-1500 Amber w/ Clear Lens
- Model No.: 010-2500 Blue w/ Clear Lens
- Model No.: 010-3500 Green w/ Clear Lens
- Model No.: 010-4400 Red w/ Red Lens
- Model No.: 010-4500 Red w/ Clear Lens
- Model No.: 010-5500 White w/ Clear Lens

Bulk Std. Pack Qty = 12
Packaged Std. Pack Qty = 6

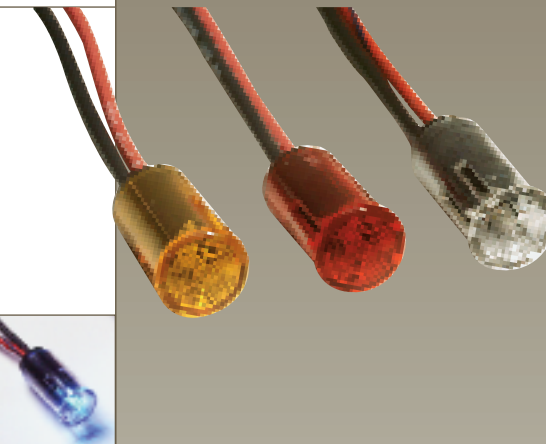

LED Bulkhead / Livewell Recess Mount Lights

- Operates 9-16 Volt DC Systems
- Size: 1.00" OD x 1.25" L x .68" ID
- Rated @ 100,000 Hours of Service Life
- Requires 11/16" (.687) Hole
- Shock and Vibration Proof
- Cool to the Touch
- No Corrosion
- Rated for Underwater Use
- 1 LED
- Patent #D439350

Product Numbers

- Model No.: 011-1500 Amber (1 LED)
- Model No.: 011-2500 Blue (1 LED)
- Model No.: 011-3500 Green (1 LED)
- Model No.: 011-4500 Red (1 LED)
- Model No.: 011-5500 White (2 LEDs)
- Model No.: 011-6500 Orange (1 LED)
- Model No.: 011-7500 Teal (1 LED)

Bulk Std. Pack Qty = 12
Packaged Std. Pack Qty = 6

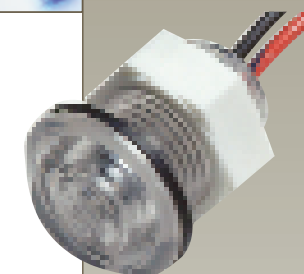

Led Surface Mount Lights

- Operates 9-16 Volt DC Systems
- Size (w/o trim ring): 2.60" L x 1.90" W x .66" D
- Rated @ 100,000 Hours of Service Life
- Shock and Vibration Proof
- Cool to the Touch
- Energy Draw 50 Milliamps
- No Corrosion
- 2 LEDs

Product Numbers

- Model No.: 200-2503 Blue
- Model No.: 200-3503 Green
- Model No.: 200-5503 White
- Model No.: 200-9902 Optional Chrome Trim Ring

Bulk Std. Pack Qty = 12
Packaged Std. Pack Qty = 6



Shown with optional chrome trim ring.



Shown Actual Size

LED 3" Silverlight™ - Surface Mount Ceiling Light – 1 Watt

- Operates on 12 Volt DC Systems
- Single LED Configuration – 1 Watt Output
- Size 3.00" L x 3.00" W x 1.00" D
- Draws .40 Milliamps
- Rated @ 50,000 Hours of Service Life
- Surface Mount Application
- Sleek Low Profile
- Shock and Vibration Proof

Product Numbers

- Model No.: 031-5000 – Black
- Model No.: 031-5100 – White
- Model No.: 031-5200 – Silver
- Model No.: 031-5300 – Brass
- Note: Interior Use Only

COLOR OPTIONS



Incandescent Compartment Light

- Operates 12 Volt DC System
- Uses 5 Watt Incandescent Lamp
- Size 5.50" L x 3.63" W x 1.25" D
- Draws .40 Amps
- Built-In Push Lens for On/Off Position
- Can be Mounted Surface or Flush Mount (bezel can be removed)
- Two Hole Mount
- UV Resistant Materials
- Two 6" Wire Leads (+/-)
- Flange Depth .250"
- E-mark and CE Approved

Product Numbers

- Model No.: 060-5000 White Light – Black
- Model No.: 060-5100 White Light – White
- Model No.: 060-5200 White Light – Chrome
- Model No.: 060-5300 White Light – Silver
- Model No.: 060-5400 White Light – Sand
- Note: Interior Use Only

COLOR OPTIONS



Recess Mount



Surface Mount

LED 3" Silverlight™ - Surface Mount Ceiling Light – 3 Watt

- Operates on 12 Volt DC Systems
- Single LED Configuration – 3 Watt Output
- Size 3.00" L x 3.00" W x 1.00" D
- Draws .70 Milliamps
- Rated @ 50,000 Hours of Service Life
- Surface Mount Application
- Sleek Low Profile
- Shock and Vibration Proof

Product Numbers

- Model No.: 033-5000 – Black
- Model No.: 033-5100 – White
- Model No.: 033-5200 – Silver
- Model No.: 033-5300 – Brass
- Note: Interior Use Only

COLOR OPTIONS



LED Compartment Light

- Operates 12 Volt DC System
- Draws .250 Milliamps
- Size 5.50" L x 3.63" W x 1.25" D
- Rated at 50,000 hours of Service Life
- Shock and Vibration Proof
- Built-In Push Lens for On/Off Position
- Can be Mounted Surface or Flush Mount (bezel can be removed)
- Two Hole Mount
- UV Resistant Materials
- Two 6" Wire Leads (+/-)
- Flange Depth .250"
- 6 LEDs

Product Numbers

- Model No.: 061-5000 LED Light – Black
- Model No.: 061-5100 LED Light – White
- Model No.: 061-5200 LED Light – Chrome
- Model No.: 061-5300 LED Light – Silver
- Model No.: 061-5400 LED Light – Sand
- Note: Interior Use Only

COLOR OPTIONS

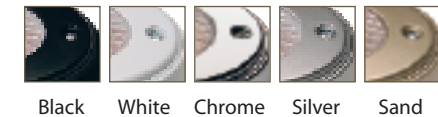

Recess Mount



Surface Mount



4-LED 3" Recess Mount Ceiling Light

- Operates on 12 Volt DC Systems
- 4 LED Configuration
- Size 3.00" L x 3.00" W x 1.00" D
- Draws .50 Milliamps
- Rated @ 50,000 Hours of Service Life
- Recess Mount Application
- Sleek Low Profile
- Shock and Vibration Proof

Product Numbers

- Model No.: 034-5000 - Black
- Model No.: 034-5100 - White
- Model No.: 034-5200 - Chrome
- Model No.: 034-5300 - Gold
- Note: Interior Use Only

COLOR OPTIONS



6" Round Dome Surface Mount Fluorescent

- 12 Volt DC Systems
- 13 Watt Fluorescent Round Lamp
- Size 6.00" L x 6.00" W x 1.00" D
- .40 Amp Draw
- 6000 Hours of Service Lamp Life
- Built-in On/Off Rocker Switch
- Non-Corrosive Aluminum Base
- Non-Yellowing Acrylic Clear Lens
- 7" Bare Wire Leads
- Mounting Hardware Included
- Separate Models available for Brass, Chrome, or White Decorative Finish

Product Numbers

- Model No.: 070-5100 Round – White Trim Ring
- Model No.: 070-5200 Round – Chrome Trim Ring
- Model No.: 070-5300 Round – Brass Trim Ring
- Note: Interior Use Only

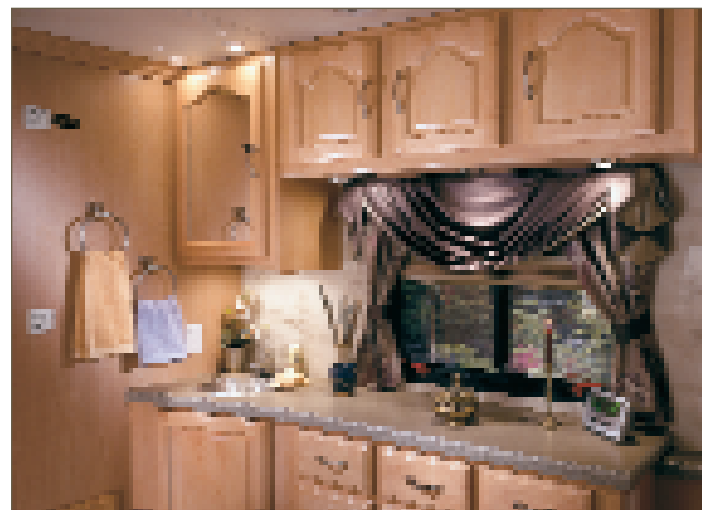

*Photos Courtesy of Coachmen

Rectangle Surface Mount Fluorescent Light

- 12 Volt DC Systems
- 13 Watt Compact Fluorescent Lamp
- Size 10.00" L x 3.50" W x 1.50" D
- .50 Amp Draw
- 6000 Hours of Service Lamp Life
- Built-in On/Off Rocker Switch
- Non-Corrosive Plastic Base
- Non-Yellowing Acrylic Clear Lens
- 7" Bare Wire Leads
- Mounting Hardware Included

Product Numbers

- Model No.: 071-5000 10" - 13 Watt
- Model No.: 071-5500 8" - 7 Watt
- Note: Interior Use Only





2 1/2" Oval LED SideMarker / Clearance Lights

- Operates 9-16 Volt DC Systems
- 2 LED Configuration
- Size 2.60" L x 1.90" W x .66" D
- 100,000 Hours of Service Life
- Sonically Sealed Polycarbonate Lens and Housing
- Shock and Vibration Proof
- P2 P3 Rated
- Impact Resistant
- Energy Draw 50 Milliamps
- Mounted Horizontally Only



Optional Gasket

Product Numbers

Model No.: 200-1100 Amber
 Model No.: 200-1500 Amber / Clear Lens
 Model No.: 200-4400 Red
 Model No.: 200-4500 Red / Clear Lens
 Model No.: 200-9905 Optional Gasket
 Bulk Std. Pack Qty = 12
 Packaged Std. Pack Qty = 6



2 1/2" Oval LED Self Grounding SideMarker / Clearance Lights

- Operates 9-16 Volt DC Systems
- 2 LED Configuration
- Size 2.60" L x 1.90" W x .66" D
- 100,000 Hours of Service Life
- Sonically Sealed Polycarbonate Lens and Housing
- Shock and Vibration Proof
- Impact Resistant
- P2 P3 Rated
- Grounded Eyelet
- Energy Draw 50 Milliamps
- Mounted Horizontally Only

Product Numbers

Model No.: 200-1103 Amber w/Grounded Eyelet
 Model No.: 200-4403 Red w/Grounded Eyelet
 Bulk Std. Pack Qty = 12
 Packaged Std. Pack Qty = N/A



2 1/2" Oval LED Stud Sidemarker / Clearance Lights

- Operates 9-16 Volt DC Systems
- 2 LED Configuration
- Size 2.60" L x 1.90" W x 1.00" D
- 100,000 Hours of Service Life
- Requires 13/32" (.406) Hole
- Stud 3/8" (.375) - 16NC x 3/4" (.750) L
- Sonically Sealed Polycarbonate Lens and Housing
- Shock and Vibration Proof
- P2 P3 Rated
- Impact Resistant
- Energy Draw 50 Milliamps
- Mounted Horizontally Only

Product Numbers

Model No.: 201-1100 Amber
 Model No.: 201-4400 Red
 Bulk Std. Pack Qty = 12
 Packaged Std. Pack Qty = N/A



OPTIONS

2 1/2" OVAL CHROME TRIM RING
 Model No.: 200-9902



Bulk Std. Pack Qty = 12
 Packaged Std. Pack Qty = N/A
 Size 3.24" L x 1.7" W x .34" D

2 1/2" OVAL SIDE MARKER GROMMET
 Model No.: 200-9900



Bulk Std. Pack Qty = 12
 Packaged Std. Pack Qty = N/A
 Size 3.25" L x 1.93" W x .50" D

2 1/2" OVAL POLISHED U-CHANNEL BRUSH GUARD
 Model No.: 200-9904 Polished



Bulk Std. Pack Qty = 12
 Packaged Std. Pack Qty = N/A
 Size 2.65" L x 1.325" W x 1.015" D (w/ gasket)

LED Sidemarker / Clearance Light With Reflectivity

- Operates 9-16 Volt DC Systems
- Single LED Configuration
- Size 2.625" L x 2.00" W x .75" D
- 100,000 Hours of Service Life
- Snap-On/Off Polycarbonate Lens
- P2 P3 Rated
- Shock and Vibration Proof
- 6" Wire Leads
- Energy Draw 50 Milliamps

Product Numbers

Model No.: 202-1100 Single LED w/ Reflectivity Amber
 Model No.: 202-4400 Single LED w/ Reflectivity Red

Bulk Std. Pack Qty = 24
 Packaged Std. Pack Qty = 6



LED Mini-Sidemarker / Clearance Lights

- Operates 9-16 Volt DC Systems
- Single LED Configuration
- Size 1.375" L x 2.50" W x .875" D
- 100,000 Hours of Service Life
- Sealed Polycarbonate Lens and Housing
- P2 P3 Rated
- Shock and Vibration Proof
- Standard Industry Connector
- Energy Draw 50 Milliamps

Product Numbers

204-1182 Amber
 204-4482 Red
 203-9900 Grommet
 203-9903 Chrome Trim Ring
 210-9902 2-Pin Male Plug-in Connector

Bulk Std. Pack Qty = 24
 Packaged Std. Pack Qty = 6*
 *Trim Ring and Grommet included



Optional plug-in connector



4" LED Sidemarker / Clearance Lights

- Operates 9-16 Volt DC Systems
- 6 LED Configuration
- Size 4.00" L x 1.125" W x .875" D
- 100,000 Hours of Service Life
- Sealed Polycarbonate Lens and Housing
- Shock and Vibration Proof
- P2 P3 Rated
- 6" Wire Leads
- Energy Draw 50 Milliamps
- 3" Mounting Centers

Product Numbers

Model No.: 205-1100 Two LED Configuration Amber
 Model No.: 205-4400 Two LED Configuration Red
 Bulk Std. Pack Qty = 24
 Packaged Std. Pack Qty = 6



6" LED Sidemarker / Clearance Lights

- Operates 9-16 Volt DC Systems
- Single LED Configuration
- Size 6.00" L x 1.75" W x 1.125" D
- 100,000 Hours of Service Life
- Sealed Polycarbonate Lens and Housing
- Shock and Vibration Proof
- P2 P3 Rated
- Standard Industry Connector
- Energy Draw 50 Milliamps

Product Numbers

Model No.: 206-1100 Single LED w/ Reflectivity Amber
 Model No.: 206-4400 Single LED w/ Reflectivity Red
 Model No.: 206-9903 Plug-in Connector

Bulk Std. Pack Qty = 24
 Packaged Std. Pack Qty = 6



Optional plug-in connector



*Photo Courtesy of Real Wheels



Shown actual size with optional rubber grommet



2" Round LED Sidemarker / Clearance Lights – Grommet Mount

- Operates 9-16 Volt DC Systems
- Single and Multi-LED Configuration
- Size 1.96" L x 1.96" W x .825" D
- 100,000 Hours of Service Life
- Sonically Sealed Polycarbonate Lens and Housing
- P2 P3 Rated
- Shock and Vibration Proof
- Standard Industry Connector
- Energy Draw 50 Milliamps
- **Patent Pending**



Optional plug-in connector

Product Numbers

- Model No.: 210-1100 Amber (1 LED)
- Model No.: 210-1101 Amber (4 LEDs)
- Model No.: 210-4400 Red (1 LED)
- Model No.: 210-4401 Red (4 LEDs)
- Model No.: 212-1100 Amber (9 LEDs)
- Model No.: 212-4400 Red (9 LEDs)
- Model No.: 210-9900 2" Protective Round Grommet
- Model No.: 210-9902 2-Pin Male Plug-in Connector

Bulk Std. Pack Qty = 24
Packaged Std. Pack Qty = 6



DOT/SAE APPROVED



Shown with optional rubber grommet



2 1/2" Round LED Sidemarker / Clearance Lights – Grommet Mount

- Operates 9-16 Volt DC Systems
- Single and Multi-LED Configuration
- Size 2.55" L x 2.55" W x .90" D
- 100,000 Hours of Service Life
- Sonically Sealed Polycarbonate Lens and Housing
- P2 P3 Rated
- Shock and Vibration Proof
- Standard Industry Connector
- Energy Draw 50 Milliamps
- **Patent Pending**



Optional plug-in connector

Product Numbers

- Model No.: 211-1100 Amber w/ Reflectivity (1 LED)
- Model No.: 211-4400 Red w/ Reflectivity (1 LED)
- Model No.: 213-1100 Amber w/o Reflectivity (13 LEDs)
- Model No.: 213-4400 Red w/o Reflectivity (13 LEDs)
- Model No.: 211-9900 2 1/2" Protective Round Grommet
- Model No.: 210-9902 2-Pin Male Plug-in Connector

Bulk Std. Pack Qty = 24
Packaged Std. Pack Qty = 6



DOT/SAE APPROVED

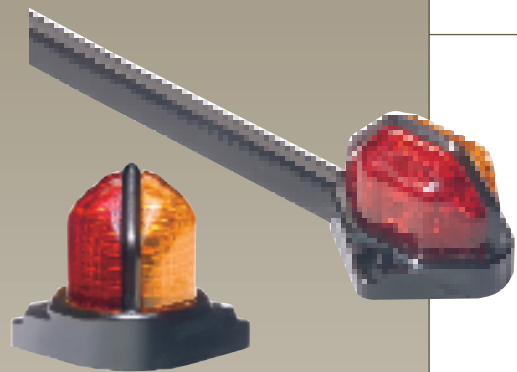

Universal LED Fender Lights

- Operates 9-16 Volt DC Systems
- Size: 1.25" L x 1.125" W x 1.375" D
- 2 LED Configuration
- 100,000 Hours of Service Life
- Sealed Polycarbonate Lens and Housing
- Shock and Vibration Proof
- Energy Draw 50 Milliamps
- Wire Application Above or Below Fender
- 6" Long Wire cover is Marked in 1" Increments for Easy Length Modification
- **Patent Pending**

Product Numbers

- Model No.: 215-0000 Amber/Red

Bulk Std. Pack Qty = 24
Packaged Std. Pack Qty = 6



DOT/SAE APPROVED

15" Slimline® LED Sidemarker / Clearance Lights

- Operates 9-16 Volt DC Systems
- 11 LED Configuration
- Size 15.5" L x 1.60" W x .80" D
- 100,000 Hours of Service Life
- Sealed Polycarbonate Light Bar
- Shock and Vibration Proof
- Energy Draw 250 Milliamps
- P2 P3 Rated
- Mounted Vertical, Horizontal, or 45 Degrees
- Impact Resistant
- **Patent Pending**

Product Numbers

- Model No.: 254-1100 Amber
- Model No.: 254-1500 Amber/Clear Lens

Bulk Std. Pack Qty = 24
Packaged Std. Pack Qty = 6



DOT/SAE APPROVED

6" Oval LED Sidemarker / Clearance Light – Grommet Mount

- Operates 9-16 Volt DC Systems
- 10 LED Configuration
- Size 6.50" L x 2.20" W x 1.00" D
- 100,000 Hours of Service Life
- Sonically Sealed Polycarbonate Lens and Housing
- Shock and Vibration Proof
- Energy Draw 250 Milliamps
- Mounted Vertical, Horizontal, or 45 Degrees
- Impact Resistant



Optional TK Plug Connector

Product Numbers

- Model No.: 260-1100 Amber
- Model No.: 260-1103 Amber w/TK Plug Connector
- Model No.: 260-1500 Amber / Clear Lens
- Model No.: 260-1503 Amber / Clear Lens w/TK Plug Connector
- Model No.: 260-9900 Protective Rubber Grommet

Bulk Std. Pack Qty = 12
Packaged Std. Pack Qty = 6



DOT/SAE APPROVED

Made in the USA

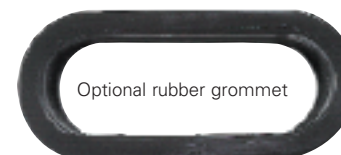

Optional rubber grommet



6" Oval LED Sidemarker / Clearance Light – Surface Mount

- Operates 9-16 Volt DC Systems
- 10 LED Configuration
- Size 7.50" L x 3.30" W x .85" D
- 100,000 Hours of Service Life
- Requires 1/2" (.50") Hole
- Sonically Sealed Polycarbonate Lens and Housing
- Shock and Vibration Proof
- Energy Draw 250 Milliamps
- Mounted Vertical, Horizontal, or 45 Degrees
- Impact Resistant



Optional TK Plug Connector

Product Numbers

- Model No.: 261-1100 Amber
- Model No.: 261-1103 Amber w/TK Plug Connector
- Model No.: 261-1500 Amber / Clear Lens
- Model No.: 261-1503 Amber / Clear Lens w/TK Plug Connector

Bulk Std. Pack Qty = 12
Packaged Std. Pack Qty = 6



DOT/SAE APPROVED

Made in the USA



Available Trim Rings

- Model No.: 261-9900 Black Trim Ring
- Model No.: 261-9901 White Trim Ring
- Model No.: 261-9902 Chrome Trim Ring



*Photo Courtesy Midsota Trailers



*Photo Courtesy Featherlite

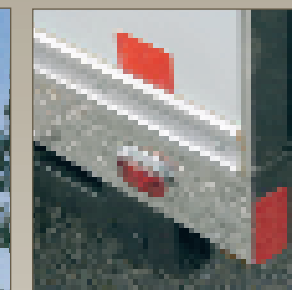

*Photo Courtesy Car-Mate Trailers



*Photo Courtesy of Featherlite Trailers

LED IDENTIFICATION LIGHT BARS

- Operates 9-16 Volt DC Systems
- Rated @ 100,000 Hours of Service Life
- Shock and Vibration Proof
- No Corrosion
- Sealed Polycarbonate Marker Lights
- Impact Resistant
- Energy Draw 150 Milliamps
- Interchangeability with Most Manufacturers
- 8.50" Mounting Centers
- Required for Trailers, Campers and Trucks Over 80" in Overall Width



• Shown actual size • Patent Pending



*Photo Courtesy of Featherlite Trailers



15" 3 - LED Identification Light Bar

- Size 15.00" L x 1.40" W x 1.185" D
- 6 LEDs Total
- ABS Housing

Product Numbers

Model No.: 220-1100 Amber
 Model No.: 220-1500 Amber with Clear Lens
 Model No.: 220-4400 Red
 Model No.: 220-4500 Red with Clear Lens

Bulk Std. Pack Qty = 24 Packaged Std. Pack Qty = 6

2 Wire

ID function
3 lights on



ID function
3 lights on



Hylite LED Identification Light Bar

- Size 13.56" L x 1.63" W x .75" D
- 3 LED Configuration
- Patent Pending

Product Numbers

Model No.: 221-1100 Amber/Amber Lens
 Model No.: 221-1500 Amber with Clear Lens
 Model No.: 221-4400 Red
 Model No.: 221-4500 Red with Clear Lens

Bulk Std. Pack Qty = 24 Packaged Std. Pack Qty = 6

2 Wire

ID function
3 lights on



ID function
3 lights on

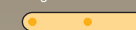



SLIMLINE® SERIES

- Operates 9-16 Volt DC Systems
- Rated @ 100,000 Hours of Service Life
- Size 15.50" L x 1.60" W x .80" D
- Shock and Vibration Proof
- No Corrosion
- Sealed Marker Lights
- Impact Resistant Polycarbonate Housing
- Energy Draw 250 Milliamps
- Interchangeability with Most Manufacturers
- 14.50" Mounting Centers



• Shown actual size • Patent Pending



*Photo Courtesy of Featherlite Trailers

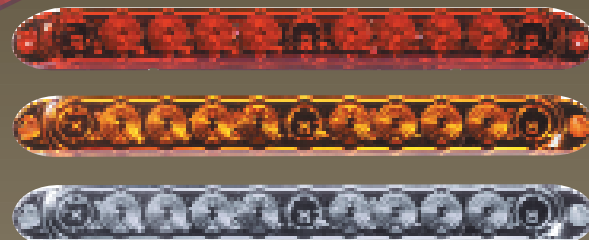

15" SlimLine® LED Identification Light Bar

- 3-LED Configuration
- Required for Trailers, Campers and Trucks Over 80" in Overall Width

Product Numbers

Model No.: 251-1100 Amber
 Model No.: 251-1500 Amber with Clear Lens
 Model No.: 251-4400 Red
 Model No.: 251-4500 Red with Clear Lens

Bulk Std. Pack Qty = 24 Packaged Std. Pack Qty = 6

2 Wire

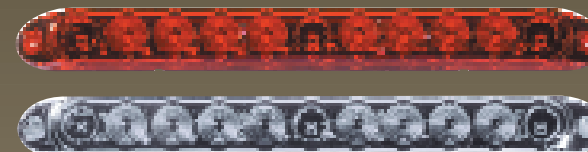

15" SlimLine® LED Identification Tri-Bar - 3rd Brake Light Bar

- 11-LED Configuration

Product Numbers

Model No.: 252-4400 Red
 Model No.: 252-4500 Red with Clear Lens

Bulk Std. Pack Qty = 24 Packaged Std. Pack Qty = 6

3 Wire

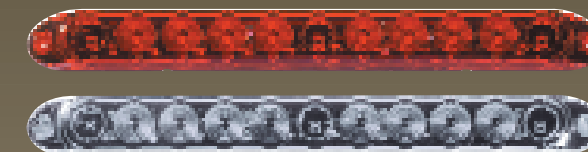

15" SlimLine® LED Identification Tri-Bar - 3rd Brake - Turn Indicator

- 11-LED Configuration

Product Numbers

Model No.: 253-4400 Red
 Model No.: 253-4500 Red with Clear Lens

Bulk Std. Pack Qty = 24 Packaged Std. Pack Qty = 6

4 Wire

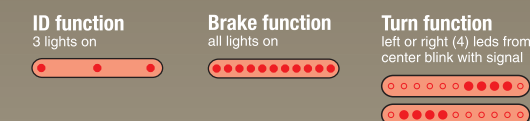

Continuous quality control and testing is a key component of the manufacturing process at Innovative Lighting.



Light shown with optional rubber grommet

4" Round LED Stop, Tail, Turn – Grommet Or Flange Mount

- Operates 9-16 Volt DC Systems
- Single LED Configuration
- Size 4.30" L x 4.30" W x 1.90" D
- 100,000 Hours of Service Life
- Sonically Sealed Polycarbonate Lens and Housing
- Energy Draw 350 Milliamps
- Industry Standard Connector
- Impact Resistant
- **Patent Pending**



Optional Plug Connector

Product Numbers

Model No.: 240-4400
Red / Grommet Mount
Model No.: 240-4500
Red - Clear Lens / Grommet Mount
Model No.: 241-4400
Red / Flange Mount
Model No.: 241-4500
Red - Clear Lens / Flange Mount
Model No.: 240-9900
Protective Rubber Grommet
Model No.: 240-9902
Plug Connector Only

Bulk Std. Pack Qty = 24
Packaged Std. Pack Qty = 6



Light shown with optional rubber grommet

4" Round LED Backup Light - Grommet Or Flange Mount

- Operates 9-16 Volt DC Systems
- Single LED Configuration
- Size 4.30" L x 4.30" W x 1.90" D
- 100,000 Hours of Service Life
- Sonically Sealed Polycarbonate Lens and Housing
- Energy Draw 350 Milliamps
- Industry Standard Connector
- Impact Resistant
- **Patent Pending**



Optional Plug Connector

Product Numbers

Model No.: 240-5500
Clear / Grommet Mount
Model No.: 241-5500
Clear / Flange Mount
Model No.: 240-9900
Protective Rubber Grommet
Model No.: 240-9902
Plug Connector Only

Bulk Std. Pack Qty = 24
Packaged Std. Pack Qty = 6

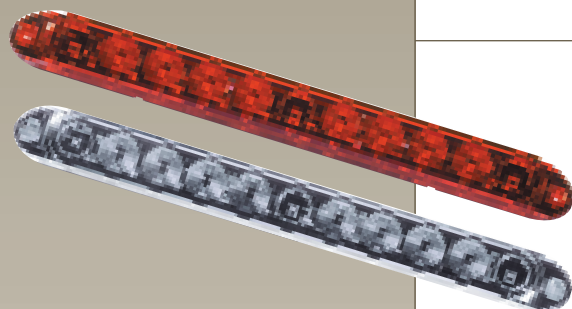

15" Slimline® LED - Stop, Tail and Turn

- Operates 9-16 Volt DC Systems
- 11 LED Configuration
- Size 15.50" L x 1.60" W x .80" D
- 100,000 Hours of Service Life
- Sealed Polycarbonate Light
- Energy Draw 250 Milliamps
- Mounted Vertical, Horizontal, or 45 Degrees
- Space / Channel Saver Design
- Impact Resistant
- **Patent Pending**



Optional TK Plug Connector

Product Numbers

Model No.: 250-4400
Red
Model No.: 250-4403
Red w/TK Plug Connector
Model No.: 250-4500
Red / Clear Lens
Model No.: 250-4503
Red / Clear Lens w/TK Plug Connector

Bulk Std. Pack Qty = 24
Packaged Std. Pack Qty = 6



6" Oval LED - Stop, Tail and Turn - Grommet Mount

- Operates 9-16 Volt DC Systems
- 10 LED Configuration
- Size 6.50" L x 2.20" W x 1.00" D
- 100,000 Hours of Service Life
- Sonically Sealed Polycarbonate Light
- Energy Draw 250 Milliamps
- Mounted Vertical, Horizontal, or 45 Degrees
- Impact Resistant



Optional TK Plug Connector

Product Numbers

Model No.: 260-4400 Red
Model No.: 260-4403 Red w/TK Plug Connector
Model No.: 260-4500 Red / Clear Lens
Model No.: 260-4503
Red / Clear Lens w/TK Plug Connector
Model No.: 260-9900 Protective Rubber Grommet

Bulk Std. Pack Qty = 12
Packaged Std. Pack Qty = 6

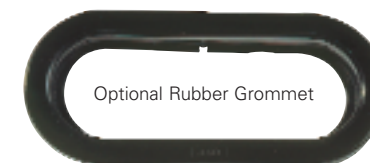

Optional Rubber Grommet



Lights Shown w/ Optional Chrome Trim Ring

6" Oval LED - Stop, Tail and Turn - Surface Mount

- Operates 9-16 Volt DC Systems
- 10 LED Configuration
- Size 7.50" L x 3.30" W x .85" D
- 100,000 Hours of Service Life
- Requires 1/2" (.500) Hole
- Sonically Sealed Polycarbonate Light
- Energy Draw 250 Milliamps
- Mounted Vertical, Horizontal, or 45 Degrees
- Impact Resistant



Optional TK Plug Connector

Product Numbers

Model No.: 261-4400 Red
Model No.: 261-4403 Red w/TK Plug Connector
Model No.: 261-4500 Red / Clear Lens
Model No.: 261-4503
Red / Clear Lens w/TK Plug Connector

Bulk Std. Pack Qty = 12
Packaged Std. Pack Qty = 6



Available Trim Rings

Model No.: 261-9900 Black Trim Ring
Model No.: 261-9901 White Trim Ring
Model No.: 261-9902 Chrome Trim Ring

LED Universal Box Light Kit

- Operates 9-16 Volts DC Systems
- Single LED Configuration Tail Light
- Includes Single LED Sidemarker
- Size 4.65" L x 4.80" W x 2.65" D
- 100,000 Hours of Service Life
- Sealed Polycarbonate Lens and Housing
- Energy Draw 350 Milliamps
- 25 Ft. Wiring Harness
- 4 Ft. Truck Harness
- License Plate Holder
- Impact Resistant
- Mounting Hardware Included

Product Numbers

Model No.: 280-4400
Red Universal Box Light
Used for Left or Right Hand Application
Bulk Std. Pack Qty = 12
Packaged Std. Pack Qty = 6

Model No.: 289-4400
Red Universal Box Light Kit
Bulk Std. Pack Qty = 1
Packaged Std. Pack Qty = 1

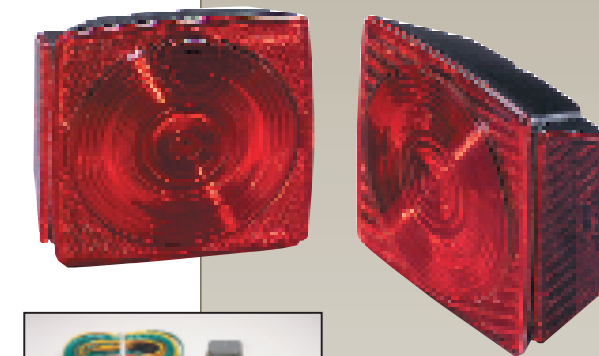

Mounting Studs on 2" Centers



*Photo Courtesy of Car-Mate Trailers



*Photo Courtesy of Extreme Custom Trailers

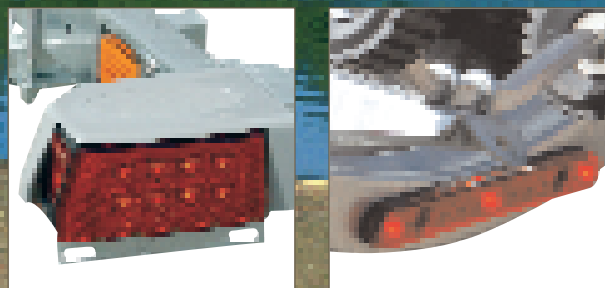

*Photo Courtesy of Aluma Trailers



LED OVER 80" TAIL LIGHTS

- Operates 9-16 Volt DC Systems
- Rated @ 100,000 Hours of Service Life
- Sealed Polycarbonate Lens and Housing
- Shock and Vibration Proof
- No Corrosion
- Submersible



*Photos Courtesy of EZ Loader

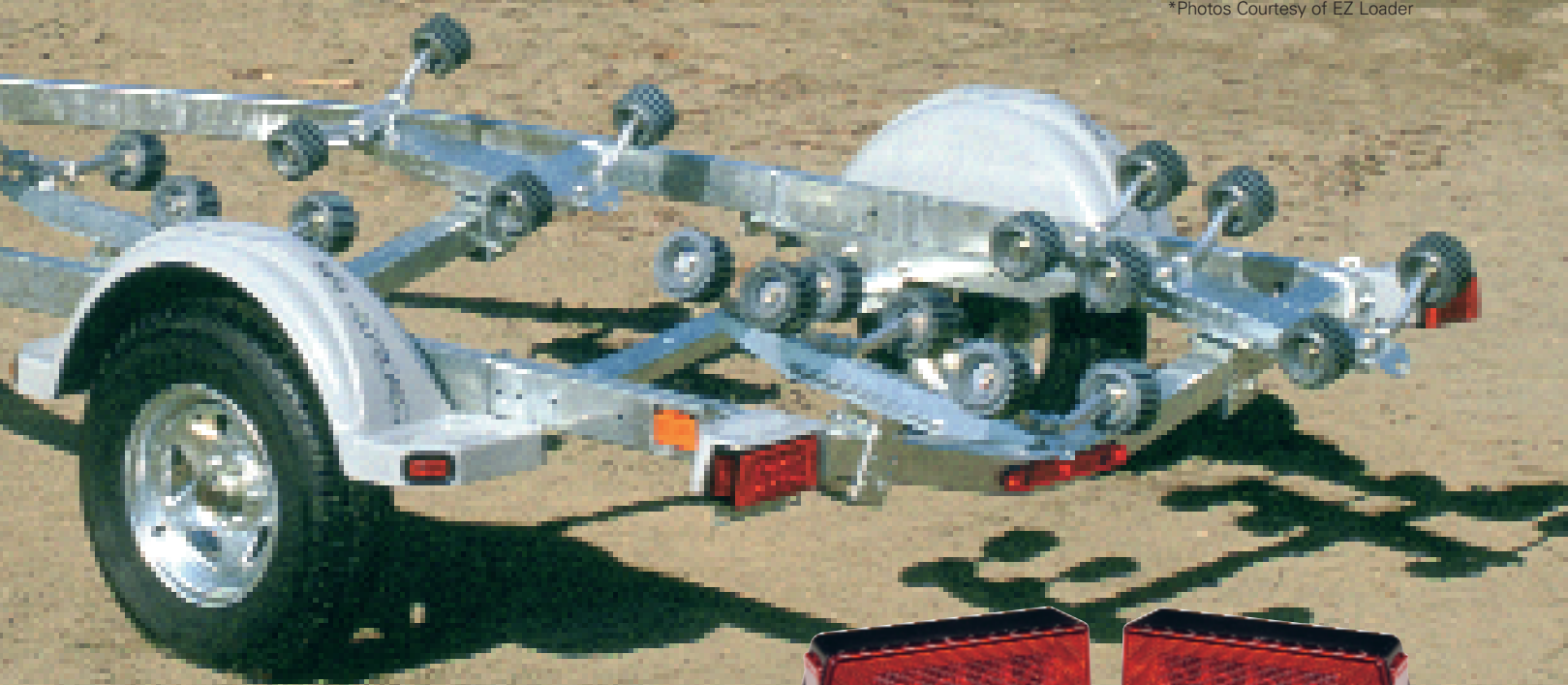

LED Over 80" Tail Light

- Energy Draw 350 Milliamps
- Size 3.50" L x 7.50" W x 7.75" D

Product Numbers

Model No.: 281-4400 Right Hand Light – Fits Under 80" Application, Red, 6 Function 9 LED Configuration
 Model No.: 282-4400 Left Hand Light w/ Lic. Illum.– Fits Under 80" Application, Red, 7 Function 12 LED Configuration
 Model No.: 285-4400 Right Hand Light – Fits Over 80" Application, Red, 6 Function 9 LED Configuration
 Model No.: 286-4400 Left Hand Tail Light w/ Lic. Illum. – Fits Over 80" Application, Red, 7 Function 12 LED Configuration

Bulk Std. Pack Qty = 12
 Packaged Std. Pack Qty = 6

LED Over 80" Tail Light Kit:

Includes 2 Tail Lights & I.D. Light Bar

Tail Lights

- 9 LED Configuration
- Energy Draw 350 Milliamps
- Size 3.50" L x 7.50" W x 7.75" D

Hylite LED Light Bar

- 3 LED Configuration
- Energy Draw 250 Milliamp
- Size 13.5625" L x 1.625" W x .75" D
- Required for Trailers, Campers and Trucks Over 80" in Overall Width

Product Numbers

Model No.: 283-4400 Tail Light Kit - Fits Under 80" Application, Red
 Model No.: 287-4400 Tail Light Kit - Fits Over 80" Application, Red
 Packaged Std. Only Qty = 1

LED Strobe Light

- Operates 6 to 80 Volt DC Systems
- Size 5.50" Tall x 3.00" Diameter
- Consumes 90% Less Power than Bulbs
- Cool to the Touch, LEDs Generate No Heat
- Two LED Configuration
- 60 Flashes Per Minute
- Shock and Vibration Proof
- 3.375" Mounting Centers
- Patent Pending

Product Numbers

600-1100 Amber
 600-2200 Blue
 600-4400 Red

Bulk Std. Pack Qty = 24 ea.



LED Low-Profile Strobe Light

- Operates 6 to 80 Volt DC Systems
- Size 4.50" Tall x 3.00" Diameter
- Consumes 90% Less Power than Bulbs
- Cool to the Touch, LEDs Generate No Heat
- Two LED Configuration
- 60 Flashes Per Minute
- Shock and Vibration Proof
- 3.375" Mounting Centers
- Patent Pending

Product Numbers

601-1100 Amber
 601-2200 Blue
 601-4400 Red

Bulk Std. Pack Qty = 24 ea.



3" Diameter Round Stick-On Class "A" Tape Reflectors

- Adheres Permanently to Flat or Curved Surfaces
- Exceeds DOT and SAE Class "A" Reflex Requirements
- Durable, Impact Resistant

Product Numbers

810-0400 Red
 810-0100 Amber

Bulk Std. Pack Qty = 50
 Packaged Std. Pack Qty = N/A

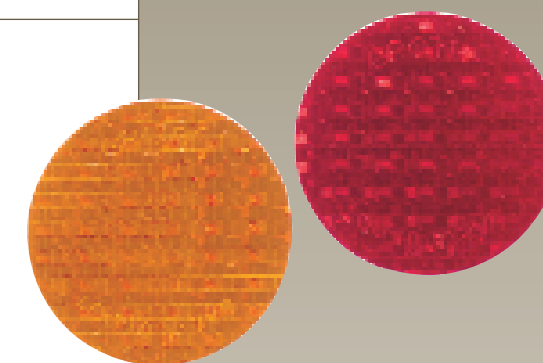

3.75" Rectangle Stick-On Class "A" Tape Reflectors

- Adheres Permanently to Flat or Curved Surfaces
- Size 3.75" L x 1.75" W
- Exceeds DOT and SAE Class "A" Reflex Requirements
- Durable, Impact Resistant

Product Numbers

812-0400 Red
 812-0100 Amber

Bulk Std. Pack Qty = 50
 Packaged Std. Pack Qty = N/A

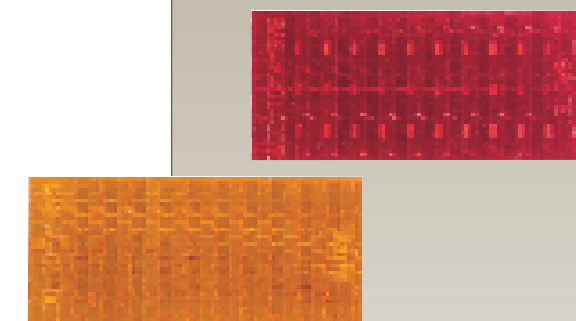



ALL-ROUND LED STERN LIGHTS

- Operates 12 Volt DC Systems
- For Powerboats Under 20 Meters (65.6 Ft.)
- Single LED Configuration
- 50,000 Hours LED Service Life
- Uses 3 Watts of Energy
- Vibration/Shock Proof
- Sealed Circuitry
- Requires 1 3/4" (1.750") Hole
- Corrosion Resistant Construction
- Durable Stainless Steel Telescopic Pole
- Easily Installed on New and Used Boats
- No Change in Current Switch Required
- Certified Ignition Protected
- IMCI Certified for ISO #8846

Innovative Lighting's LED Navigation Lights are USCG Certified and NMMA Listed.

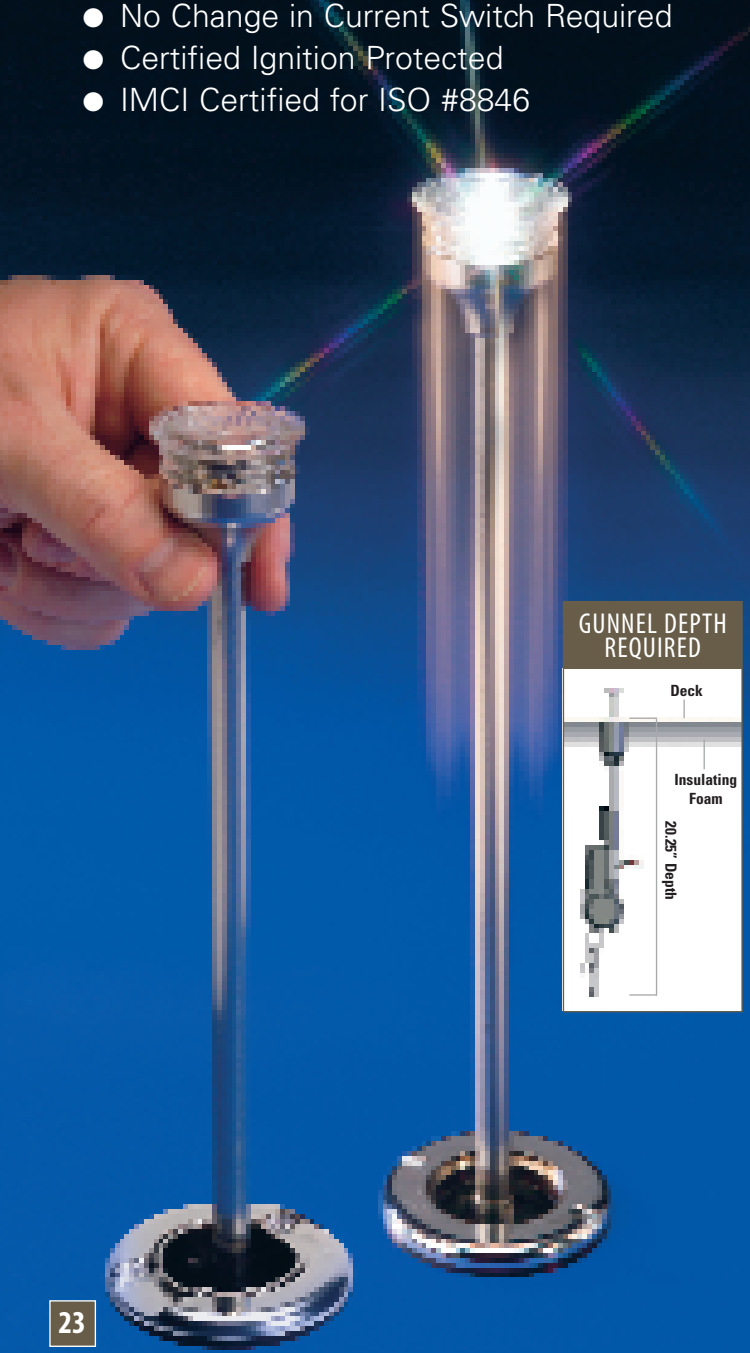

GUNNEL DEPTH REQUIRED

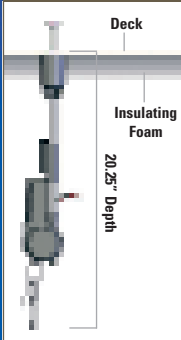

Powerlight Motorized Stern Light

- Automated Up/Down Operation
- Patent #5304993, 5398026

Model No.: 504-1200 4'Ft. - Chrome Deck Ring
 Model No.: 505-1200 5'Ft. - Chrome Deck Ring
 Model No.: 506-1200 6'Ft. - Chrome Deck Ring

Bulk Std. Pack Qty = 10 Packaged Std. Pack Qty = 1

Extend-A-Light Manual Stern Light

- Easy Pull-up/Down Hand Operation
- Patent #5304993, 5398026

Model No.: 514-1200 4'Ft. - Chrome Deck Ring
 Model No.: 515-1200 5'Ft. - Chrome Deck Ring
 Model No.: 516-1200 6'Ft. - Chrome Deck Ring

Bulk Std. Pack Qty = 10 Packaged Std. Pack Qty = 1

REPLACEMENT PARTS

Model No.: 504-9900 Anchor Bracket for PowerLight and Extend-A-Light
 Model No.: 504-9902 Replacement All-round Lens
 Model No.: 504-9903 Replacement Chrome Deck Ring

All-Round LED Pedestal Mount

- Operates 12 Volt DC Systems
- For Powerboats Under 20 Meters (65.6 Ft.)
- Single LED Configuration
- 50,000 Hours of Service Life
- Uses 3 Watts of Energy
- Transparent Lens and Frosted Globe
- Shock and Vibration Proof
- Equipped with Stainless Steel Shaft
- Fixed Mounting Base

Model No.: 500-0100
 4" LED All-round Pedestal Mount
 Model No.: 500-0200
 8" LED All-round Pedestal Mount

Bulk Std. Pack Qty = 12
 Packaged Std. Pack Qty = 6





TWO-MILE LED NAVIGATION LIGHTS

- Operates 9-16 Volt DC Systems
 - For Powerboats Under 20 Meters (65.6 Ft.)
 - 50,000 Hours of Service Life
 - Transparent Lens
 - Cool to the Touch
 - Stainless Steel Housing
 - Hard Wire Leads
 - Permanent Snap-On Cover
 - Available in 12 & 24 volt
 - **Patent Pending**
- European Approvals Pending

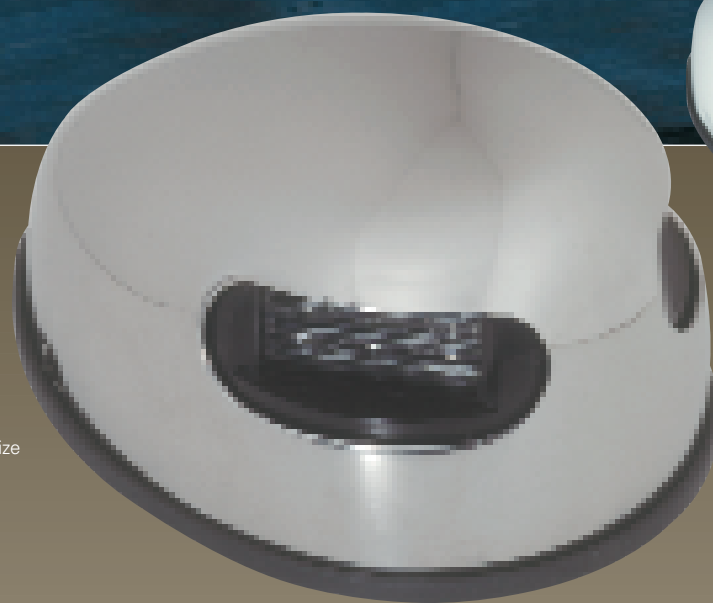

Shown Actual Size



Two-Mile LED Combination Sidelights Deck Mount

- 6 LED Configuration
- Size 3.45" L x 2.6" W x 1.65" D
- Uses 1 Watt of Energy

Model No.: 550-1100
Enamel Baked White Stainless Steel
Model No.: 550-1200
Polished Stainless Steel

Bulk Std. Pack Qty = 24
Packaged Std. Pack Qty = 6

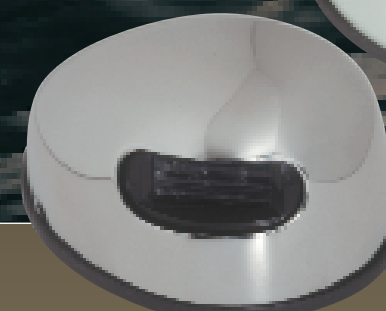

Two-Mile LED Sidelights Deck Mount

- 3 LED Configuration
- Size 3.45" L x 2.6" W x 1.65" D
- Uses 1/2 Watt of Energy

Model No.: 552-1100
Starboard and Port Enamel Baked White Stainless Steel
Model No.: 552-1200
Starboard and Port Polished Stainless Steel
Packaged Only= 1 Pair

Model No.: 552-2100
Starboard Enamel Baked White Stainless Steel
Model No.: 552-3100
Port Enamel Baked White Stainless Steel
Model No.: 552-2200
Starboard Polished Stainless Steel
Model No.: 552-3200
Port Polished Stainless Steel

Bulk Std. Pack Qty = 24
Packaged Std. Pack Qty = 6



Two-Mile LED Sidelights Vertical Mount

- 3 LED Configuration
- Size 3.375" L x 2.3125" W x 1.5" D
- Uses 1/2 Watt of Energy

Model No.: 554-1100
Starboard and Port Enamel Baked White Stainless Steel
Model No.: 554-1200
Starboard and Port Polished Stainless Steel
Packaged Only= 1 Pair

Model No.: 554-2100
Starboard Enamel Baked White Stainless Steel
Model No.: 554-3100
Port Enamel Baked White Stainless Steel
Model No.: 554-2200
Starboard Polished Stainless Steel
Model No.: 554-3200
Port Polished Stainless Steel

Bulk Std. Pack Qty = 24
Packaged Std. Pack Qty = 6



Innovative Lighting's LED Navigation Lights are USCG Certified and NMMA Listed.

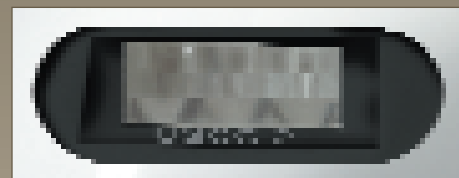



"SETS" Piezo Electronic Drop In Hidden Horn

- 12 or 24 volt DC Systems
- For Vessels Under 12 Meters (39.4 Ft.)
- Size 4.345" L x 2.27" W x 2.63" D
- Uses "SETS" Horn Technology
- Draws Less Than 1/2 Amp
- Unit Is Polarity Protected
- Solid State With No Moving Parts
- Built-in Water Evacuation Drainage System
- Requires 2 1/4" Hole
- Mounting Gasket Included
- Patent #6559758B2

Product Numbers
 Model No.: 540-0000 Black
 Model No.: 540-0100 White
 Model No.: 540-0700 Cream
 Bulk Std. Pack Qty = 24
 Packaged Std. Pack Qty = 6



Model No.: 540-9900
 Optional Stainless Steel Grill Overlay



"SETS" Piezo Electronic Hull Mount Horn

- 12 or 24 Volt DC Systems
- For Vessels Under 12 Meters (39.4 Ft.)
- Size 5.34" L x 3.4" W x 3.2" D
- Uses "SETS" Horn Technology
- Draws Less Than 1/2 Amp
- Unit Is Polarity Protected
- Solid State With No Moving Parts
- Built-in Water Evacuation Drainage System
- Requires Jig Saw or Router
- Mounting Gasket Included
- Patent #6559758B2

Product Numbers
 Model No.: 541-0000 Black
 Model No.: 541-0100 White
 Bulk Std. Pack Qty = 24
 Packaged Std. Pack Qty = 6



Model No.: 541-9900
 Optional Stainless Steel Grill Overlay



"SETS" Piezo Electronic Deck Mount Horn

- 12 or 24 Volt DC Systems
- For Vessels Under 12 Meters (39.4 Ft.)
- Size 5" L x 3.74" W x 2.50" D
- Uses "SETS" Horn Technology
- Draws Less Than 1/2 Amp
- Unit Is Polarity Protected
- Solid State With No Moving Parts
- Rope Shedding Design
- Forward Facing Presentation
- Mounting Gasket Included
- Patent #6559758B2

Product Numbers
 Model No.: 542-0000 Black
 Model No.: 542-0100 White
 Bulk Std. Pack Qty = 24
 Packaged Std. Pack Qty = 6



"SETS"

Synchronous Excitation Transfer System combines two electronic sound elements into a single canister.

Innovative Lighting's Electronic Horns are USCG Certified and NMMA Listed

Hand Held Electronic Horns - Battery Operated

- Weatherproof
- Solid State Electronics
- Shock Resistant Construction
- Size 7" H X 2.75" W
- Meets United States Coast Guard Requirements
- Requires One 9-Volt Battery (Not Included)
- Patent #D488736

Contains No CFC's

No Haz-Mat

No Leaking Or Limited Shelf Life



Model No.: 545-2010
 Portable Hand Held Electronic Sport Horn with Cradle (Yellow Case)
 Bulk Std. Pack Qty = N/A
 Packaged Std. Pack Qty = 6

Model No.: 545-5010
 Portable Hand Held Electronic Signaling Horn with Cradle (Blue Case)
 Bulk Std. Pack Qty = N/A
 Packaged Std. Pack Qty = 6



Shown with Mounting Cradle





Marine Portable LED Navigation Lights

- Requires 4 "AA" Batteries (Not Included)
- Molded One Piece White Body Construction
- Shock Resistant Neoprene Accents
- Rated at 100,000 Hours LED Service Life
- Uses 90% Less Energy than Incandescent
- Sealed Heavy Duty On/Off Switch
- Insert Molded Brass Threaded Mounting Bushings
- Removable Lamp Carriage Assembly
- Fully Buoyant
- 1 LED

Product Numbers

Model No.: 560-1110
Bow Light w/ Screw On/Off Suction Cup

Model No.: 560-2110
Stern Light w/ Screw On/Off Suction Cup

Bulk Std. Pack Qty = 24
Packaged Std. Pack Qty = 6



Waterproof "O" Ring Sealed Battery Housing



Model No.: 560-1111
Bow Light w/ Universal "C" clamp



Model No.: 560-2113
Stern Light w/ 18" Pole and Universal "C" and "U" clamp

Model No.: 560-1814
Bow Light w/ Universal "C" clamp Camouflage Body

Model No.: 560-2813
Stern Light w/ 18" Pole and Universal "C" and "U" clamp Camouflage Body

Model No.: 560-1112
Bow Light w/ 2" Stud Mount Inflatable Base with attached Lanyard and Stainless Steel "D" Ring



Model No.: 560-2112
Stern Light w/ 2" Stud Mount Inflatable Base with attached Lanyard and Stainless Steel "D" Ring



Marine Portable Navigation Lights

- Requires 4 "AA" Batteries (Not Included)
- Molded One Piece Gray Body Construction
- Shock Resistant Neoprene Accents
- Super-Brite Krypton Lamp
- Sealed Heavy Duty On/Off Switch
- Insert Molded Brass Threaded Mounting Bushings
- Removable Lamp Carriage Assembly
- Fully Buoyant
- 1 Krypton Bulb

Product Numbers

Model No.: 560-1600
Bow Light w/ Suction Cup

Model No.: 560-2600
Stern Light w/ Suction Cup

Bulk Std. Pack Qty = 24
Packaged Std. Pack Qty = 6

Model No.: 560-1601
Bow w/ Universal "C" clamp

Model No.: 560-2603
Stern w/ 18" Pole and Universal "C" and "U" clamp



Model No.: 560-1602
Bow Light w/ 2" Stud Mount Inflatable Base with attached Lanyard and Stainless Steel "D" Ring

Model No.: 560-2602
Stern Light w/ 2" Stud Mount Inflatable Base with attached Lanyard and Stainless Steel "D" Ring



Replacement Parts

Sonic Welded Lenses



Model No.: 560-9900
Replacement Bow Lens Assembly

Model No.: 560-9902
Replacement Stern Lens Assembly

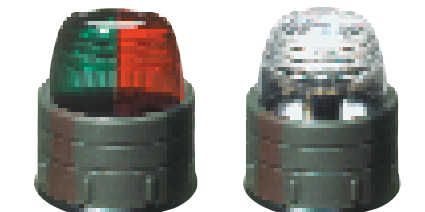

Model No.: 560-9901
Replacement Bow Lens Assembly Camo

Model No.: 560-9903
Replacement Stern Lens Assembly Camo

Aluminum Mounting Brackets



Model No.: 560-9905
Replacement Universal "C" clamp and Mounting Hardware

Model No.: 560-9908
Replacement 18" Pole w/ "U" clamp and Mounting Hardware

Replacement Lamps



Model No.: 560-9910
LED Lamp Only

Model No.: 560-9912
LED Lamp with Optical Dispersion Lens (To convert Incandescent to LED)

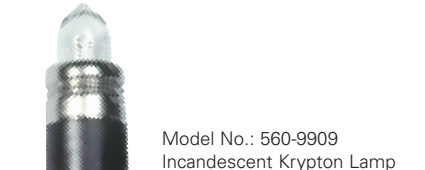

Model No.: 560-9909
Incandescent Krypton Lamp

Suction and Inflatable Mounts



Model No.: 560-9904
Suction Cup

Model No.: 560-9906
2" Stud Mount Inflatable Base with attached Lanyard and Stainless Steel "D" Ring

DOCKING / HULL / BACK-UP LIGHTS

- 12-Volt DC Systems
- 50-Watt Halogen Lamp
- Draws 4 Amps Each
- Sealed Built-in Rear Heat Sink
- Thermal Insulated Wires
- Pyrex Optical Lens
- Spring Loaded Lamp Assembly
- Removable Screw On/Off Lens
- Water Tight Gaskets Included
- Patent #D472654

316
STAINLESS
STEEL



Product Numbers

Mirror Polish Finish
Model No.: 580-0200
Polished - Pair
Model No.: 580-9902
Replacement Polished Lens
with Gasket

Bulk Std. Pack Qty = 12
Packaged Std. Pack Qty = 1

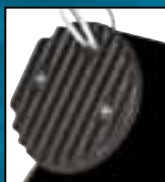

Sealed Built-in Rear Heat Sink

*Photo Courtesy of J.C. Manufacturing Inc.



Product Numbers

Enamel Baked Black Gloss Finish
Model No.: 580-0000
Black - Pair
Model No.: 580-9900
Replacement Black Lens
with Gasket

Product Numbers

Enamel Baked White Gloss Finish
Model No.: 580-0100
White - Pair
Model No.: 580-9901
Replacement White Lens
with Gasket



LIGHT SIZING



Deck / Dock / Shore Station LED Lighting Kit

- 12 Volt DC Systems
- Ideal For Illuminating Deck, Docks, and Walkways
- Low Cost Insurance For Lighted Pathways
- Non-Attracting Bug Amber Colored LED Lights
- Optional Wireless Remote System Available

Kit Includes:

- 1 AC/DC Transformer w/60 Ft. Of Attached Wire
- 1 UL-Listed Junction Box
- 4 three LED Step Lights
- 12 single LED Accent Lights
- 32 Stainless Steel Screws
- 34 Wire Snap Quick Connects
- 40 Insulated Staples

Product Numbers

Model No.: 090-1000
Amber LED Lighting Kit
Model No.: 090-5000
White LED Lighting Kit

Packaged: 1 Kit



Dual Function Wireless Remote System

- 12 Volt DC Systems
- Two Function Remote (up to 5 amps per function)
- Operates Up To 75 Feet From Boat / RV / Deck / Dock / Walkway
- Custom Applications Available - Up To 40 Amps
- Conformal Coated Circuit Board
- Weather Tight Receiver Can Be Mounted Anywhere
- Re-programmable Transmitter Key Fob Available
- F.C.C. Approved #OAVTX315

Product Numbers

Model No.: 590-0000
10 Amp Dual Function
Wireless Remote System
Model No.: 590-9900
Replacement 10 Amp
Dual Transmitter Key Fob
Bulk Std. Pack Qty = 12
Packaged Std. Pack Qty = 6



INNOVATIVE USES

- Boats**
- Lighted Docks**
- RV's**
- Lighted Decks**
- Lighted Walk-Ways**

Innovative Lighting offers attractive, eye-catching Point-of-Purchase (POP) retail clamshell packaging to better serve our aftermarket network.



LED (Light Emitting Diode) Limited Lifetime Warranty:

Innovative Lighting Corporation (ILC) extends a Limited Lifetime LED Lamp Warranty to the original purchaser that ILC's sealed LED Lamp is free from defects in workmanship and/or materials only. Any product developing such defect in material or workmanship within this period will be repaired or replaced with a like product, at our option (ILC) providing it is sent to us, transportation charges prepaid, along with US\$5.00 to cover the cost of handling. Please note; this is not a repair charge. Proof-of-Purchase date to ILC at our Roland, Iowa, factory must accompany return. ILC does not warrant any incandescent electric lamps (bulbs) free against defects and or performance.

The LED LIMITED LIFETIME WARRANTY DOES NOT APPLY TO SEVERE APPLICATIONS such as buses, construction equipment and off-road vehicles. These applications are examples only and are not all inclusive of each exclusive application. Many chemicals and /or cleaners are incompatible with ILC's LED products; therefore, the LED Limited Lifetime Lamp Warranty does not apply to damage associated with incompatible chemicals and cleaners. The ILC LED lamps are to remain intact, free from physical abuse, not subject to improper installation or modification. Any violation of these conditions will void this LED Limited Lifetime Lamp Warranty.

This LED Limited Lifetime Warranty is not transferable and applies to the original installation of the sealed LED lamps for as long as the original consumer/purchaser owns the vehicle/boat/trailer (LIFETIME).



One Year Limited Product Warranty:

ILC Limited Product Warranty is ONE (1) YEAR on all other components, including battery lights, extend-a-light and power light products, and trailer lighting products. Any product developing such defect in material or workmanship within this period will be repaired or replaced with a like product, at our option (ILC) providing it is sent to us, transportation charges prepaid, along with US\$5.00 to cover the cost of handling. Please note; this is not a repair charge. Proof-of-Purchase date to ILC at our Roland, Iowa, factory must accompany return. ILC does not warrant any incandescent electric lamps (bulbs) free against defects and or performance.

Chrome plated products showing evidence of peeling will be repaired or replaced at ILC's discretion. Chrome showing signs of wear due to debris, rock chips, pitting, etc... will not be covered.

This warranty is void if the product warranted has been damaged by accident or unreasonable use, neglect, improper service or other cause not arising out of defects in material or workmanship.



Five Year Limited Product Warranty:

ILC Limited Product Warranty is FIVE (5) YEARS on docking lights, horn related products and navigation lights (excluding extend-a-lights and powerlights) and their components. Any product developing such defect in material or workmanship within this period will be repaired or replaced with a like product, at our option (ILC) providing it is sent to us, transportation charges prepaid, along with US\$5.00 to cover the cost of handling. Please note; this is not a repair charge. Proof-of-Purchase date to ILC at our Roland, Iowa, factory must accompany return. ILC does not warrant any incandescent electric lamps (bulbs) free against defects and or performance.

This warranty is void if the product warranted has been damaged by accident or unreasonable use, neglect, improper service or other cause not arising out of defects in material or workmanship.





INNOVATIVE
LIGHTING inc.®

P.O. Box 366

109 Progressive Avenue

Roland, Iowa 50236

Phone: 515-388-1011





Facsimile: 515-388-5549

Email: sales@InnovativeLight.com

Web: InnovativeLight.com

Toll Free: 800-949-4888

Proud Member of the Following Associations:

	NMMA <i>National Marine Manufacturers Association</i>
	ABYC <i>American Boating Yacht Council</i>
	NATM <i>National Association of Trailer Manufacturers</i>
	SAE <i>Society of Automotive Engineers</i>
	TSEI <i>Transportation Safety Equipment Institute</i>